

CRYPTO CODE

Model CC-2500

Stand-Alone Access Control System

**Revision-2.0
(10/97)**

Introduction

INTRODUCTION

The CC-2500 is a versatile access control system that supports one door and offers many of the features of a larger computer based system. Some of the features are listed below.

- Three keypad choices
- Supports Crypto Key readers
- 29 or 250 code capacity
- One 10 Amp relay output
- Alarm relay output
- Exit button capability
- Timed or latching relay
- Three alarm modes
- Easy keypad programming
- Operational battery back-up
- 12VDC strike power
(24VDC optional)

There are many creative ways to use all the features of the CC-2500. If you have any questions, or need advice on your particular application, call MONITEQ at 1-703.569-0195 or 1-800-989-9891.

SPECIFICATIONS

Power required120VAC, 60Hz, 50 W
(plug-in AC adapter included)

Output.....12VDC, 1.0A max
(24VDC, 2.0A optional)

Battery back-up.....12VDC
(24VDC optional)
(battery not included)

Control dimensions12 x 9 x 4.5

Code capacity
CC-2500.....29
CC-2500/250.....250

Relay ratingSPDT, 10 Amp

Keypads supportedany Crypto Code
6-wire keypad

Keypad cable length250' max

Readers supported..... Crypto Chip
(Dallas Semiconductor Touch Memory)

Crypto Chip cable length.....100" max

Installation Section

Material Required To Begin

- 1) One CC-2500 controller with AC adapter (plus battery if operational back-up is required).
- 2) One electrical release (strike, magnet, etc).
- 3) One keypad.
- 4) 6-conductor/22-awg cable for keypad (20' included).
- 4) 2-conductor/18-awg cable for electrical release.
- 5) Any additional hardware to meet the requirements of the individual installation (i.e. exit buttons, door contacts, alarms, etc.).

Installation

Mount the keypad at a convenient height next to the door to be controlled.

Mount the electric strike or magnet on the door frame per the instructions included with the device.

Mount any magnetic switches, exit buttons, remote releases, etc. required to complete the application.

Mount the CC-2500 control box in a convenient location within the secured area. The keypads are supplied with a 20' cable, so the control box optimally should be located within 20' of the keypad and near a 120 VAC outlet.

See *Figure 1* and *Figure 2* for interconnection of devices and board settings.

After all the connections are made and the system is powered, the green system light on the circuit board should be flashing and the left red light on the keypad should be on.

A diode with one red and one black wire attached is included in the parts bag. To prevent electrical spikes from the strike or magnet, you should attached the red wire to the positive side of the strike or magnet and the black wire to the negative side (see figure 2).

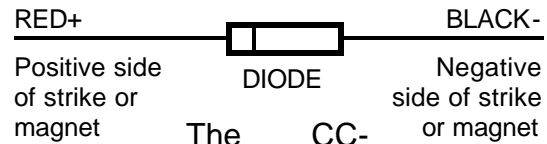

The CC-2500 is supplied mounted in a metal enclosure for wall mounting. Also included is a battery charger for system back-up (battery not included) and an AC Power Transformer. The CC-2500 board has a 12 VDC output (24VDC optional) for powering electric strikes, magnets or accessories.

Installation

CC-2500 CIRCUIT BOARD

Figure 1 below details the CC-2500 Circuit Board.

Jumpers J1 & J2 (not used)

Jumpers J3 & J4

Set as shown. Up position disables programming.

Jumper J5

Jumper J5 should be left in the C25 position.

Jumpers J6, J7, & J8

Jumpers J6, J7, and J8 set terminals 18, 21, and 24 as Normally Closed contacts (NC) or solid-state switches to ground (T) respectively.

Fuses

Replace only with the same value 20mm fuse as shown in figure 1.

Reset

The reset button should be pressed if the Green LED (L4) is not flashing.

Initialize

Used to default to factory parameters. See page 8 for details.

Green LED (L4)

The green LED (L4) is the power indicator. If the board is powered, this LED should be flashing.

Red LED's (A, B, & ALARM)

The red LED's illuminate when the corresponding relay is energized.

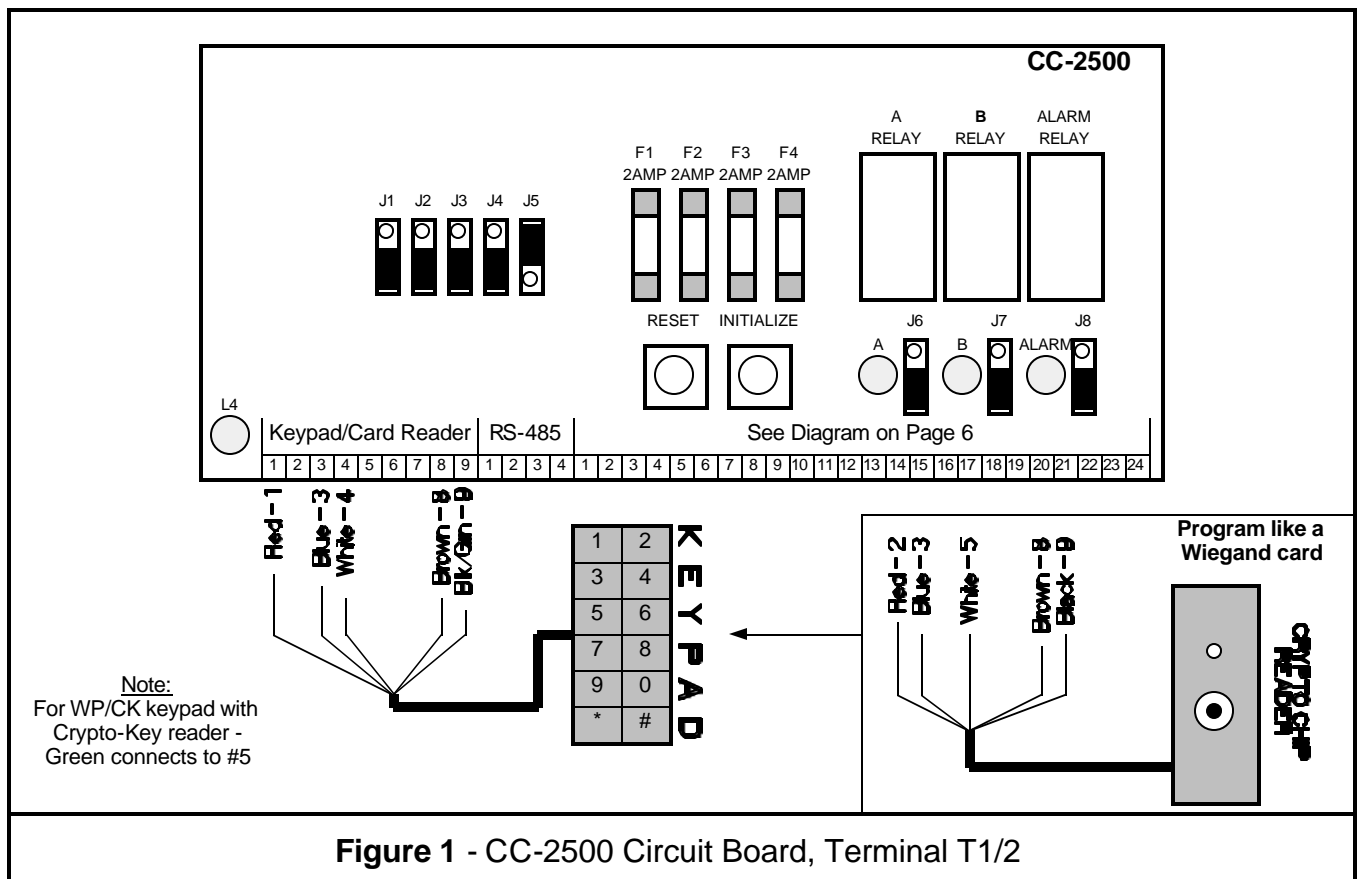

Installation

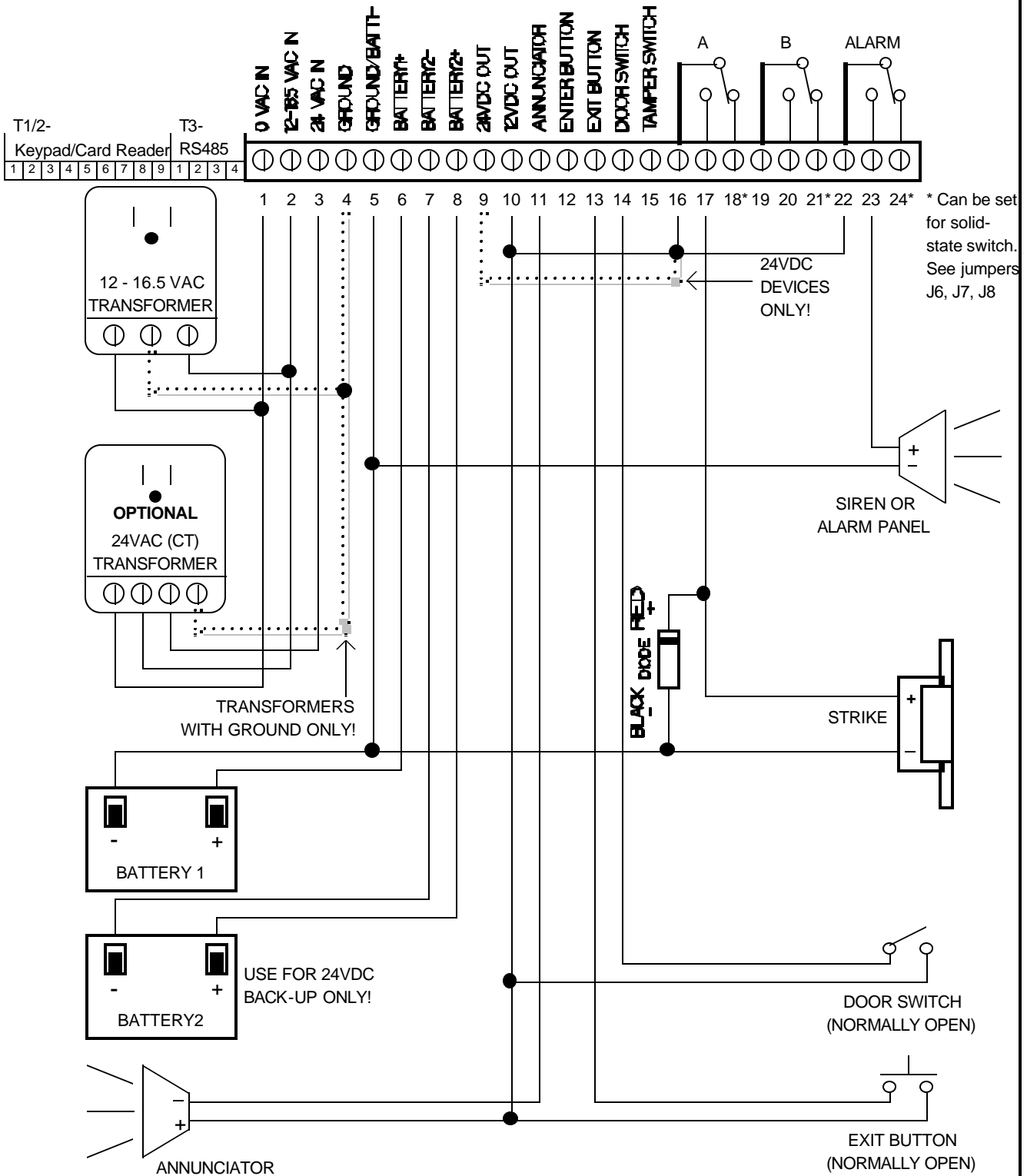

Figure 2a - CC-2500 Circuit Board (Strike and Accessories)

Installation

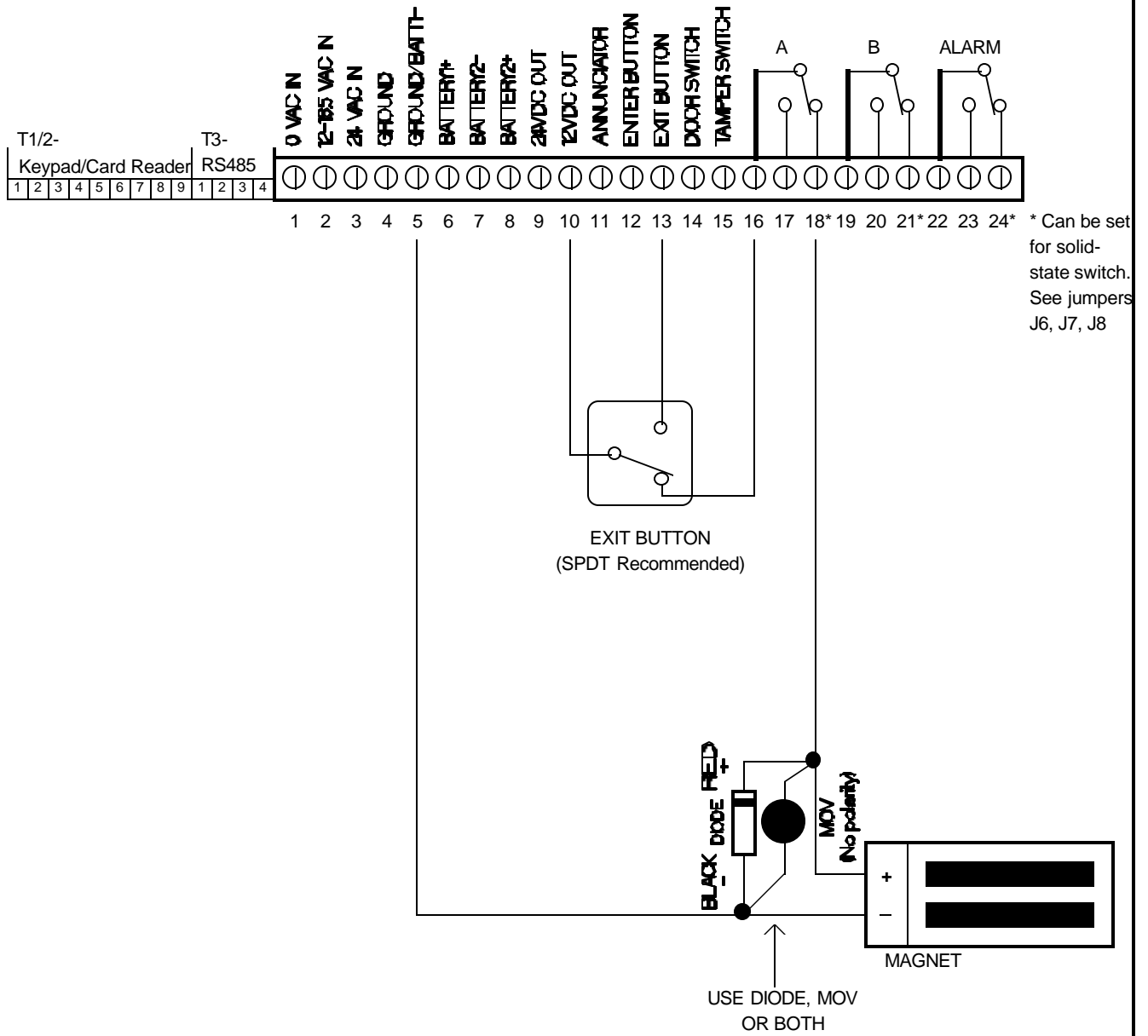

Figure 2b - CC-2500 Circuit Board (Magnetic Release)

Installation

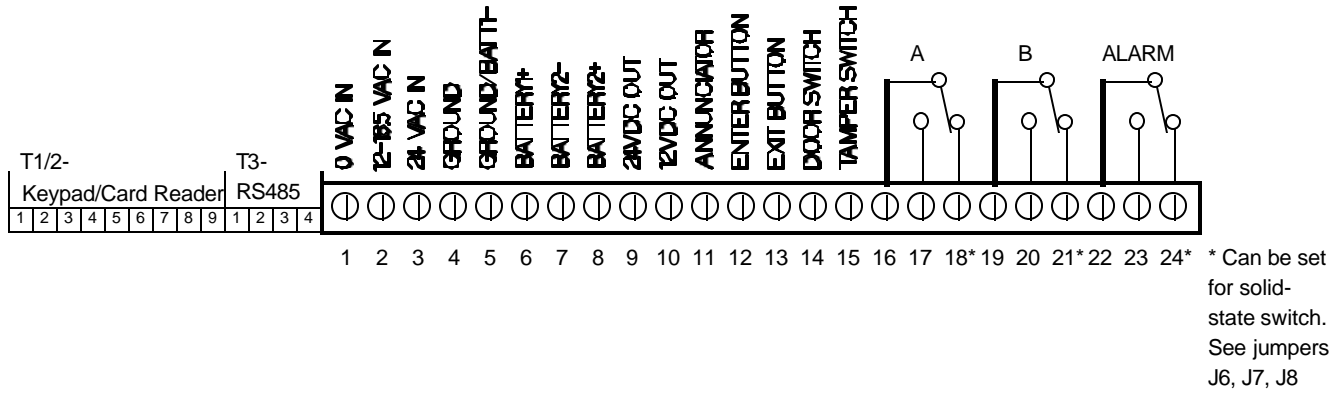

Figure 2c - CC-2500 Circuit Board (Scratch Pad)

Installation Section

Terminal connections

See *Figure 2* on previous pages for diagram of the CC-2500 circuit board terminations.

- 1 **0 VAC:** Connect to one side of 12-16.5VAC or 24VAC(CT) transformer.
- 2 **12-16.5VAC:** Connect to other side of 12-16.5VAC or Center Tap (CT) of 24VAC transformer.
- 3 **24VAC:** Connect to other side of 24VAC transformer (if used).
- 4 **GROUND:** Connect to ground terminal of 12VAC or 24VAC transformer (if available). This connection is helpful - it provides an earth ground to the system.
- 5 **BATT1(-):** Connect to negative of battery 1. This is also system ground.
- 6 **BATT1(+):** Connect to positive of battery 1.
- 7 **BATT2(-):** Connect to negative of battery 2 (if used). Use only for 24 volt back-up.
- 8 **BATT2(+):** Connect to positive of battery 2 (if used). Use only for 24 volt back-up.
- 9 **24VDC:** 24 volts DC to power 24 volt strike or magnet (if 24VAC transformer is used).
- 10 **12VDC:** 12 volts DC to power 12 volt strike, exit switch, door switch, or accessories.
- 11 **ANNUNCIATOR:** Connect to negative side of annunciator buzzer (if used).
- 12 **ENTER:** Connect to one side of enter button (if used).
- 13 **EXIT:** Connect to one side of exit button or remote release (if used).
- 14 **DOOR:** Connect to one side of door switch (if used).
- 15 **TAMPER:** Connect to one side of tamper switch (if used).
- 16 **A-COMMON:** Relay A common contact - dry.
- 17 **A-N/O:** Relay A normally open contact - dry.
- 18 **A-N/C:** Relay A normally closed contact or solid state switch to ground. Set jumper accordingly (see figure 1).
- 19 **B-COMMON:** Relay B common contact - dry.
- 20 **B-N/O:** Relay B normally open contact - dry.
- 21 **B-N/C:** Relay B normally closed contact or solid state switch to ground. Set jumper accordingly (see figure 1).
- 22 **ALARM-COMMON:** Alarm relay common contact - dry.
- 23 **ALARM-N/O:** Alarm relay normally open contact - dry.
- 24 **ALARM-N/C:** Alarm relay normally closed contact or solid state switch to ground - set jumper accordingly (see figure 1).

Programming

Programming

To begin programming, follow the steps shown on the chart on the next page.

If at any time you wish to exit the program mode or start an entry over, press the # button.

During programming, the keypad will beep once for acceptance of an entry, or will beep three times if an error was made. If an error was made, press # and start over.

Default Information

There are two ways to erase all the information in the memory and return to the default (factory) parameters.

- 1) Press and continue to hold down the "INITIALIZE" button on the circuit board. While holding the button down, momentarily press the "RESET" button. Continue holding the "INITIALIZE" button until the green light begins to flash again.
- 2) Use the programming chart - command "02".

The default (factory) parameters are:

Master code:	1-2-3-4
Relay A time:	10 seconds
Relay A latch:	Off
Relay A Shunt:	Off
Alarm delay:	30 seconds
Alarm reset mode:	Door
Alarm time:	30 seconds
Duress mode:	Off
Penalty count:	10
Penalty time:	30 seconds

Note: The Master code will not open the door. You must add a User code (see page

7) to open the door.

Operation

The keypad has two lights - one red and one green. The red light indicates that the system is powered and the door is locked. After entering a valid code the red light will go out and the right green light will come on indicating the the door is released.

The alarm relay is activated by any of the following conditions.

- Door propped (door switch required)
 - Forced entry (door switch required)
 - Duress (if programmed ON)
 - Penalty (if programmed ON)
 - Tamper (tamper switch required)
-
- To deactivate alarm, close door or enter code depending on mode.
 - To deactivate alarm, enter valid code.

The annunciator output is activated by pressing the # button on the keypad. A buzzer must be installed for this function.

The exit button or remote release button will release the door as long as the switch is closed and for the programmed relay time after the switch is opened.

To activate the duress alarm, add "1" to the user code. Example: if user code is 1-2-3-4, the duress code would be 1-2-3-5. A duress code will open the door and activate the alarm. To deactivate the alarm, enter another valid code or wait for the time-out.

Programming

To Program	Commands Comments	
Delete all Memory	* XXXX (master) * 00 *	! Caution - Irreversible
Change Master Code	* XXXX (master) * 01 * YYYYY(new master) *	
Default All Info	* XXXX (master) * 02 *	See previous page for info
Delete All User Codes	* XXXX (master) * 10 *	! Caution - Irreversible
Add User Code	* XXXX (master) * 11 * YYYYY(code) * 1 (relay-A) or 2 (B) or 3 (A&B) *	
Delete User Code	* XXXX (master) * 12 * YYYYY(code) *	
Add Batch Codes	* XXXX (master) * 16 * YYYYY(code) * 1 (relay-A) or 2 (B) or 3 (A&B) * repeat italics until complete #	
Delete Batch Codes	* XXXX (master) * 17 * YYYYY(code) * repeat italics #	
Add Sequential Codes	* XXXX (master) * 18 * YYYYY(1st code) * 1 or 2 or 3 (increment) * ZZZ (# of codes) * 1 *	
Relay A Open Time	* XXXX (master) * 20 * YYY (seconds) *	Maximum = 255 seconds
Relay A Latch	* XXXX (master) * 21 (on) or 22 (off) *	"On" to make relay A toggle
Relay A Shunt	* XXXX (master) * 23 (on) or 24 (off) *	Requires a door switch
Relay B Open Time	* XXXX (master) * 25 * YYY (seconds) *	Maximum = 255 seconds
Code Length	* XXXX (master) * 34 * YY (length) *	Range = 1 to 12 digits
Alarm Delay Time	* XXXX (master) * 40 * YYY (seconds) *	Maximum = 255 seconds
Alarm Reset Mode	* XXXX (master) * 41 (door) or 42 (valid code) *	
Alarm Time	* XXXX (master) * 43 * YYYYYY (seconds) *	Maximum = 65,000 seconds
Duress	* XXXX (master) * 50 (on) or 51 (off) *	Must erase all codes first
Penalty Count	* XXXX (master) * 55 * YYY (# of errors) *	Maximum = 255
Penalty Time	* XXXX (master) * 56 * YYY (seconds) *	Max = 255 seconds, 0 = OFF
Crypto Key Mode	* XXXX (master) * 32 * and * XXXX (master) * 36 *	! Do BEFORE adding codes

SYSTEM SETUP PARAMETERS

Use the chart below to record your system setup parameters. It is helpful to fill out the chart prior to actually programming the system.

PARAMETER	INPUT
MASTER CODE (4 digits - keep master code secret)	
RELAY A OPEN TIME (maximum = 255 seconds)	
RELAY A LATCH (ON or OFF)	
RELAY A SHUNT (ON or OFF)	
RELAY B OPEN TIME (maximum = 255 seconds)	
CODE LENGTH (range 1-12 digits)	
ALARM DELAY TIME (maximum = 255 seconds)	
ALARM RESET MODE (DOOR or VALID CODE)	
ALARM TIME (maximum = 65,000 seconds)	
DURESS MODE (ON or OFF)	
PENALTY COUNT (maximum = 255)	
PENALTY TIME (maximum = 255, 0 = OFF)	

Troubleshooting Section

PROBLEM

No flashing green light when board is powered.

Keypad does not beep or have any lights.

Keypad works, but system does not respond to master code or user code.

User code works, but door does not release.

System works sometimes but then stops working.

SOLUTIONS

Disconnect everything except the transformer. Check the transformer connections and the AC fuses. Check that there is 12-16 VAC on terminals 1 and 2. Check that there is 12-18 VDC on terminals 5 and 10.

Check cable and any splices for proper order and good connections.

Use the "INITIALIZE" button on the circuit board to default the system parameters. Check that *-1-2-3-4-* activates the right green light on the keypad.

Check wiring. Most installations require a jumper wire between terminal 16 (A com) and terminal 10 (12VDC).

Connect a diode or MOV across the strike or magnet being careful about polarity. A diode or MOV protects the circuit board from electrical spikes generated by strikes and magnets and is included in the accessory bag.

One Year Limited Warranty

MONITEQ products are warranted to be free from factory defects for a period of one year from the date of shipment. The repair or replacement of a defective part shall be at the option of the factory when the product is shipped prepaid and insured by the owner. This warranty is void in cases of abuse, misuse, mishandling, or repair by unauthorized persons. This warranty is given in lieu of all other warranties expressed or implied. MONITEQ is not liable for incidental or consequential damages resulting from the operation or failure of this product. The warranty recognizes any and all rights you may have under appropriate state law.



MONITEQ Research Laboratories, Inc.
7640 Fullerton Road
Springfield, VA 22153
703-569-0195