

Crypto Lock

Model CC-8421

Ver. 2, Rev. 1.0

Access Control System

INSTRUCTION MANUAL



MONITEQ, Inc.

Tel: 1-800-989-9891

TABLE OF CONTENTS

1. INTRODUCTION.....	4
2. SPECIFICATIONS	7
3. SUPPLIED EQUIPMENT	8
4. FUNCTIONS OF CONTROLS AND INDICATORS	9
4.1 KEYPAD.....	9
4.2. CONTROL UNIT	9
5. INSTALLATION and POWER SUPPLY SETTINGS	10
5.1 GENERAL	10
5.2 INSTALLATION.....	10
5.3 POWER SUPPLY SETTINGS	11
6. PROGRAMMING	13
6.1 General	13
6.2 The Programming Mode	13
6.3 Initial Settings	13
6.4 PIN Management.....	14
6.5 Door Monitoring	14
6.5.1 Open Duration	14
6.5.2 Anti-Follow	14
6.5.3 Door Propped Alarm	15
6.5.4 Forced Door Alarm	15
7. OPERATION	16
8. KEY PAD INSTALLATION TEMPLATE.....	17

1. INTRODUCTION



Figure 1-1, The CC-8421 Control Unit, Keypad, and Wall Transformer

The Crypto-Lock Model CC-8421 (Version 2, Revision 1.0) is a versatile, easily installed and operated single door access control system. It provides reliable, secure keypad access control using a single 3, 4, 5 or 6-digit PIN code for all users. It can be used with standard magnetic locks and electric strikes and can be used to operate both a magnetic lock and an electric strike on the same door.

The system, pictured in Figure 1-1, includes a built-in 12Vdc and 24Vdc power supply to power electric strikes and magnetic

locks, eliminating the need for a separate power supply unit. It provides the voltages and currents required to reliably open standard locking devices. (Heavy duty locks such as Von Duprin* rim latch retraction units and Sargent & Greenleaf BRUTE* electric locks require high in-rush currents that exceed the specification of the CC-8421. The Moniteq Model CC-8521A is recommended for use with these locks.)

The power supply includes a battery charging and monitoring circuit that automatically maintains batteries in a fully charged condition and activates audible and visual warnings when the charge level is low. Two 12V, 7AH sealed lead acid batteries (not included) can be housed within the Control Unit enclosure.

The time duration during which the lock remains released after entry of the valid PIN is adjustable from 3 to 60 seconds. An invalid PIN "penalty" feature provides for ignoring all keypad entries for 3 to 60 seconds after an invalid digit is entered. Further, if five or more successive invalid PINs are entered the penalty time is set to 60 seconds until the valid PIN is entered. This greatly reduces the possibility of gaining access by guessing PIN codes, and is particularly effective when shorter PIN lengths are used.

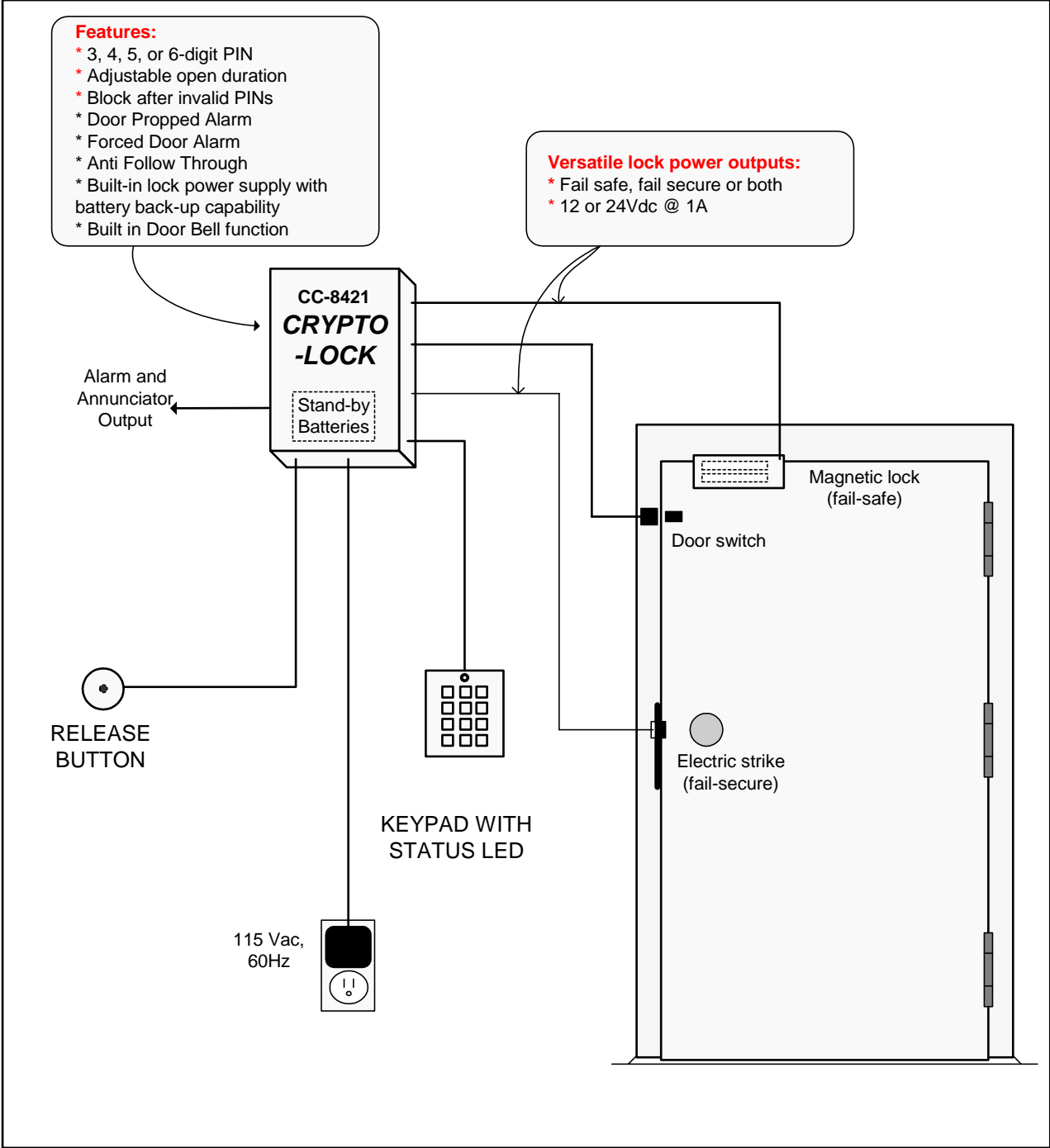

Figure 1-2, Typical Application of the Model CC-8421 Access Controller

The keypad unit includes a green LED that illuminates when the lock is released.

The # button on the keypad activates an annunciator in the control unit and also generates an output signal for activating an external visible or audible device.

Installation and set-up are readily accomplished using the wiring diagram affixed to the inside of the enclosure door and also contained in this manual. A slide switch sets the lock output voltage (12 or 24 V).

A programming mode (which can only be activated from within the Control Unit) allows authorized personnel to set the PIN and other functions (see Table 5-1) using the keypad.

A typical installation of the CC-8421 is illustrated in Figure 1-2.

**Von Duprin is a registered trademark of the Ingersoll-Rand Company; Brute is a registered trademark of Sargent & Greeleaf, Inc.*

2. SPECIFICATIONS

Power required: 115 Vac, 60 Hz, 25W

Output: 12 or 24 Vdc, 0.8 A

Relay contacts: 10A, SPDT (Form C)

Battery back-up: 12Vdc or 24Vdc, automatic transfer and charging (batteries optional, Moniteq p/n CC-BATT)

Battery monitoring: Warning lamp, beeper and output signal activate when battery is low

PIN code length: 3, 4, 5 or 6 digits

Open duration: Adjustable, 3 to 60 seconds

Penalty function: Invalid PIN attempts temporarily disable operation and can be set to sound an alarm.

Penalty time: Adjustable, 3 to 60 seconds, set to 60 seconds after five invalid PIN attempts

Remote release input: Dry contact closure

Door monitoring functions: Door propped open alarm, forced door alarm

Keypad cable: 10-conductor, #22
Supplied cable: 10 ft., 10-cond., #22
Maximum length: 1,000 ft.

Enclosure: 19 gauge steel, powder coated paint, gray color, knock-outs for conduit, and cam-lock (included), holes for padlock (not included)

Dimensions: 12H x 9W x 4.5D in.

Options available:

CC-BATT: 12Vdc, 7AH rechargeable battery (two required for 24Vdc operation)

3. SUPPLIED EQUIPMENT

The CC-8421 consists of two main units, the Keypad and the Control Unit, and various accessories and mounting hardware to facilitate installation. The table below lists all of the items that comprise the Model CC-8421 along with a brief description of each to aid in their identification and use.

QTY	ITEM	PURPOSE
1	Control Unit	Main processor and power supply
1	Keypad with 10' cable	Accepts PIN code entries
1	Manual, Crypto Lock CC-8521B (this manual)	Installation and operating instructions
1	CC-24CT Wall transformer with 10' cable	Connection to AC power
2	Threaded rod, #8 X 12"	Keypad mounting, thru-wall
1*	Cam Lock w/ two keys	Lock Control Unit door
2*	Screw, slotted, Sheet metal, #6, 1/2"	Hold Control Unit door closed
2*	Battery cables, #18 AWG, black/red	Connect batteries to Lock Driver Board
1*	Diode (1N4007) with red and black wires	Connect at lock to suppress spikes
2*	Fuse, 2A, Slo-Blo	Spares
4*	Hex Nut, #8	Keypad mounting
2*	Acorn nut, #8	Keypad mounting, thru-wall
6*	Lock washer, #8	Keypad Mounting
2*	Washer, #8, 1-1/2 in. dia.	Keypad mounting, thru-wall
8*	Pan head combo drive screw, #8 x 1-1/2"	Keypad and Control Unit Mounting
2*	Bushing, black nylon, 7/8"	Protects cables going into Control Unit
2*	Anchor, nylon, adhesive back, 1" x 1"	Secure wires within Control Unit
6*	Tie wrap, nylon, 4"	Secure cables within Control Unit
1	Template, Keypad mounting holes	Keypad installation

* Items packed in poly bag

4. FUNCTIONS OF CONTROLS AND INDICATORS

4.1 KEYPAD

Normal Operation Mode:

Keys 1 through 0: Used to enter the PIN code.

Key: Sounds an annunciator in the Control Unit and also activates a 12 Vdc output signal for use with an external device. * Key - Not used

Green LED indicator:

Illuminates when the door is released.

Flashes when any key is pressed

Programming Mode:

Keys 1 through 0: Used to enter programming codes

Key: Used to terminate the programming mode.

* Key: Used as a delimiter for programming codes and parameters.

Green LED indicator:

Programming mode: Flashes continuously

Valid programming entry: Single flash

Invalid programming entry: Three flashes

4.2. CONTROL UNIT

PENALTY Indicator LED: Illuminates when the invalid PIN penalty feature is activated.

AC POWER Indicator LED: Indicates that the system is AC powered.

BATTERY Indicator LED: Indicates that system is battery powered.

OUTPUT VOLTAGE switch (24V or 12V): Selects the voltage that will operate the locking device(s) attached to the system.

LOW BAT Indicator LED: Indicates that the battery is low.

Beeper: See Table 6-1, Alarm Sequences

F1 and F2: 24 Vac power, 2A Slo Blo

F3: Batteries, 2A Slo Blo

F4: Lock current, 2A Slo Blo

5. INSTALLATION and POWER SUPPLY SETTINGS

5.1 GENERAL

Installation of the CC-8421 consists of mounting the Keypad and Control Unit, connecting the Keypad, wall transformer, external lock and other devices to the Control Unit, and installing the batteries (optional) in the Control Unit. A switch in the Control Unit is used to set the lock voltage to either 12 or 24 Vdc. Programming includes setting the valid PIN code, open duration time, invalid PIN penalty time, and options for activating door propped and forced door alarms.

5.2 INSTALLATION

1) Mount the Keypad approximately 36 to 44 inches above the floor on the unsecured side of the door. Use the template on page 18 to mark and drill holes. Through-wall mounting can be accomplished using the supplied #8 threaded rod, acorn nuts, hex nuts, and 1-1/2" washers. Alternatively, the Keypad can be mounted using the four #8 x 1-1/2" pan head combo drive screws.

2) Mount the electric lock, strike and/or magnet according to the manufacturer's instructions.

3) Mount the Control Unit on the secure side of door in an area convenient to the door and an electrical outlet. Four #8 x 1-1/2" pan head combo drive screws are provided for this purpose.

4) If required, install the supplied Cam Lock on the enclosure door in the knockout hole provided for that purpose. Alternatively, if a padlock (not supplied) is to be used, remove the two 3/8" nylon plugs from the padlock holes. The padlock's shackle must first be inserted through the hole on the side of the enclosure, the door can then be closed so that the padlock hole on the door also passes over the shackle. If the door does not need to be locked, the two supplied #6 x 1/2" screws can be used in the holes on the door edge to hold it closed.

Note

All cables passing through the knockout holes in enclosure must be protected from chafing using the supplied 7/8" nylon grommets. Route all cables to avoid the space in the bottom of the Control Unit that can be occupied by batteries. Nylon tie wraps and self-adhering nylon anchors are supplied for this purpose.

5. Connect the Keypad to the Control Unit as shown in Figure 5-1. Ten feet of cable is supplied with the Keypad. The Keypad can be

located up to 1,000 feet from Control Unit using additional cable. (Requires 10 conductors, #22 or larger).

6. Connect the electric lock, strike and/or magnet as shown in Figure 5-1.

7. If used, connect a Release Button (not supplied), and external 12Vdc annunciator (not supplied), as shown in Figure 5-1. Note that an internal annunciator in the Control Unit will sound when the Keypad's # button is pressed and for all alarm functions.

8. If the Door Propped or Forced Door alarm functions will be used, connect the door switch to the Control Unit as shown in Figure 5-1.

9. If used, install and connect the batteries as shown in Figure 5-1 using the two supplied battery cables. Use only 12V, 1.2 to 7AH re-chargeable sealed lead acid batteries. (Moniteq Type CC-BATT)

10. Connect the 24 Vac center tapped wall transformer to T3 in the Control Unit as shown in Figure 5-1.

5.3 POWER SUPPLY SETTINGS

1. Set the OUTPUT VOLTAGE switch in accordance with the voltage (12 or 24 Vdc) rating of the lock(s) being used.

NOTE

If both a magnetic lock and an electric strike/lock are used both must have the same voltage rating.

2. Connect the CC-24CT Wall Transformer to an appropriate source of AC power (120Vac, 60 Hz) and verify that the AC POWER indicator in the Control Unit illuminates.

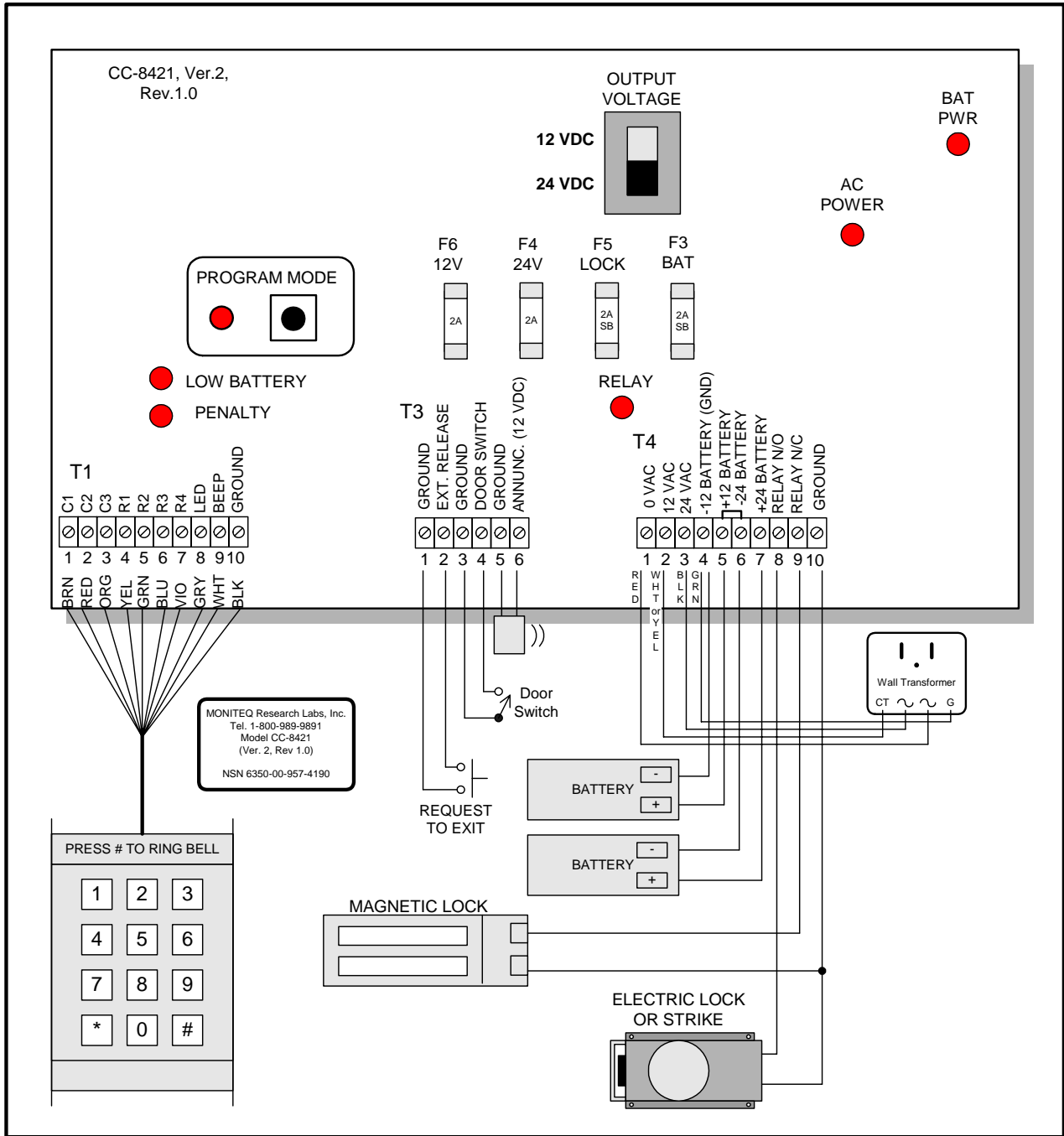

Figure 5-1, Wiring Diagram for External Devices

6. PROGRAMMING

6.1 General

Programming includes setting the valid PIN, open duration time, invalid PIN penalty time, and options for the door propped, and forced door alarms. These settings are accessible only by first placing the Control Unit into Programming Mode and then entering the programming sequences listed in Table 6-1 on the keypad.

Programming sequences are entered on the keypad in the form *FC*N*, where FC is a 2-digit Function Code and N is a numeric value.

Table 6-1 Programming Sequences

Function	Sequence	Range of N	Default
PIN MANAGEMENT FUNCTIONS			
Set Defaults	*00*	N/A	N/A
Delete PIN	*10*	N/A	N/A
Set PIN	*11*N*	000 to 999, 9999, 99999 or 999999	No valid PIN
Penalty Time	*12*N*	5 to 60 (seconds)	5 seconds
Invalid PIN Alarm	*13*N*	0=Off, 1=On	Off
DOOR MANAGEMENT FUNCTIONS			
Open Duration	*20*N*	01 to 60 (sec.)	5 seconds
Anti-Follow Through	*21*N*	0=Off, 1=On	Off
Door Propped Alarm Delay Time	*22*N*	1 to 255(sec.)=On, 0=Propped Alarm Off	Off
Door Propped Alarm Duration	*23*N*	15 to 255(sec), 0=Door Closed	Door Closed
Forced Door Alarm	*24*N*	0=Off, 1=On	Off

6.2 The Programming Mode

Enter the Programming Mode by pressing the PROGRAM MODE button inside the Control Unit. The red PROGRAM indicator lamp in the Control Unit and the green indicator lamp on the keypad will both begin to flash, verifying that the Programming Mode is active. To exit the Programming Mode and return to the Normal Operation Mode press either the PROGRAM MODE button again or the # key on the keypad. The system will also revert to Normal Mode if no keys on the keypad are pressed for 5 minutes.

6.3 Initial Settings

During a new installation or if you are uncertain as to what settings have been programmed previously, it is recommended that the

default values for all PIN and Door Monitoring settings be set by entering *00* on the keypad.

6.4 PIN Management

A new valid PIN code can be set only when the system is in the Programming Mode.

To establish a new valid PIN, enter *11*N*, where N is any number containing either 3,4,5 or 6 digits.

To delete the current valid PIN enter *10*. (This effectively disables the keypad since no PIN entry can then be used to release the door.)

The CC-8421 includes an invalid PIN penalty feature that protects against an unauthorized user gaining entry by entering successive guesses of the correct PIN. When an invalid PIN is entered, the system then ignores all further PIN entries for 5 to 60 seconds. The default value is 5 seconds. To change the Penalty Time enter *56*N*, where N is from 5 to 60 (seconds).

After five successive invalid PIN entries the penalty time is automatically reset to 60 seconds until the valid PIN is entered. This feature increases the average time it would take to successfully guess the valid PIN and is particularly effective in protecting PINs with only 3 or 4 digits.

An Invalid PIN Alarm feature sounds an alarm (three short beeps) whenever an invalid PIN is entered. This feature is disabled by default. To enable enter *58*1*. To disable enter *58*0*.

6.5 Door Monitoring

The system includes a number of functions that make it possible to monitor the status of the door during operation. With the exception of the Open Duration function, these features require that a door position switch be installed on the door and connected to the Control Unit as illustrated in Figure 5-1.

6.5.1 Open Duration

The Open Duration is the time period during which the door is released (unlocked) after either a valid PIN is entered on the keypad or the remote release button is pressed. The default Open Duration time is 5 seconds. To change the Open Duration time enter *20*N*, where N is from 5 to 60 (seconds).

6.5.2 Anti-Follow

The Anti-Follow mode is provided to prevent the door from being re-opened a second time during the Open Duration time period. This function is disabled by default. To enable Anti-Follow enter

*23*1*. To disable Anti-Follow enter *23*0*. When this function is enabled the door re-locks immediately after it closes, regardless of the Open Duration setting.

6.5.3 Door Propped Alarm

The Door Propped Alarm function sounds an alarm when the door remains open for more than a period of time from 1 to 255 seconds (Door Propped Alarm Delay Time) or until the door is closed. This function is disabled by default. To enable the Door Propped Alarm set the Door Propped Alarm Delay Time by entering *22*N* where N= 1 to 255 seconds. To disable the Door Propped Alarm enter *22*0*.

The Door Propped Alarm Duration can be set to sound continuously either until the door closes, or until a time out period expires or the door closes, whichever occurs first. Enter programming code *23*0* to set the Door Propped Alarm to sound until the door closes. To have the Door Propped Alarm sound until a time out period expires or the door closes whichever occurs first, enter *23*N* where N=15 to 255 seconds(Door Propped Alarm Duration).

6.5.4 Forced Door Alarm

The Forced Door Alarm function sounds an alarm if the door is opened without being released by the system. This function is disabled by default. To enable the Forced Door Alarm enter *24*1*. To disable Forced Door Alarm enter *24*0*. The Forced Door Alarm is silenced by entering the valid PIN on the keypad or by disabling the Forced Door Alarm function by entering programming code *24*0*.

7. OPERATION

To operate the CC-8421, enter the valid 3, 4, 5, or 6 digit PIN code on the keypad. When the valid PIN code is entered, the green LED on the Keypad will illuminate and the door lock will release.

The CC-8421 Keypad has a built-in visitor annunciator button. Pressing the # key causes an annunciator to sound in the Control Unit. If an external sounding device is connected as shown in Figure 5-1 it will also sound when this button is pressed.

If an incorrect PIN code is entered the system will enter a penalty mode and will not recognize any digits for a time period of from 5 to 60 seconds. If five successive invalid PINs are entered the penalty time is set to 60 seconds until the valid PIN is entered. After the penalty time has elapsed the unit will return to normal operation and entering the valid PIN code on the Keypad will release the door.

If the external Release Button has been installed it can be used by an attendant to release the lock from a location on the secure side of the door.

Various alarm situations activate different sequences of sounds on the beeper in the Control Unit. If an external annunciator is connected to the system it will sound the same sequences as the beeper in the Control Unit. Table 7-1 lists these alarm sequences and their meaning.

Table 7-1, Alarm Sequences

Alarm Type	Alarm Sequence		Silenced by:
Visitor	Activated by # button on keypad		
Invalid PIN	- - - - -	Five short beeps	After five short beeps
Door Propped	_____	Continuous long beeps	Door closed or time out set by code *23N*
Forced Door	- - - - -	Continuous short beeps	Valid PIN or code *24*0*
Low Battery	- - - - -	Chirp every 15 seconds	Apply AC power

8. KEY PAD INSTALLATION TEMPLATE

CRYPTO-LOCK Model CC-8421 Ver. 2 Keypad Mounting Template

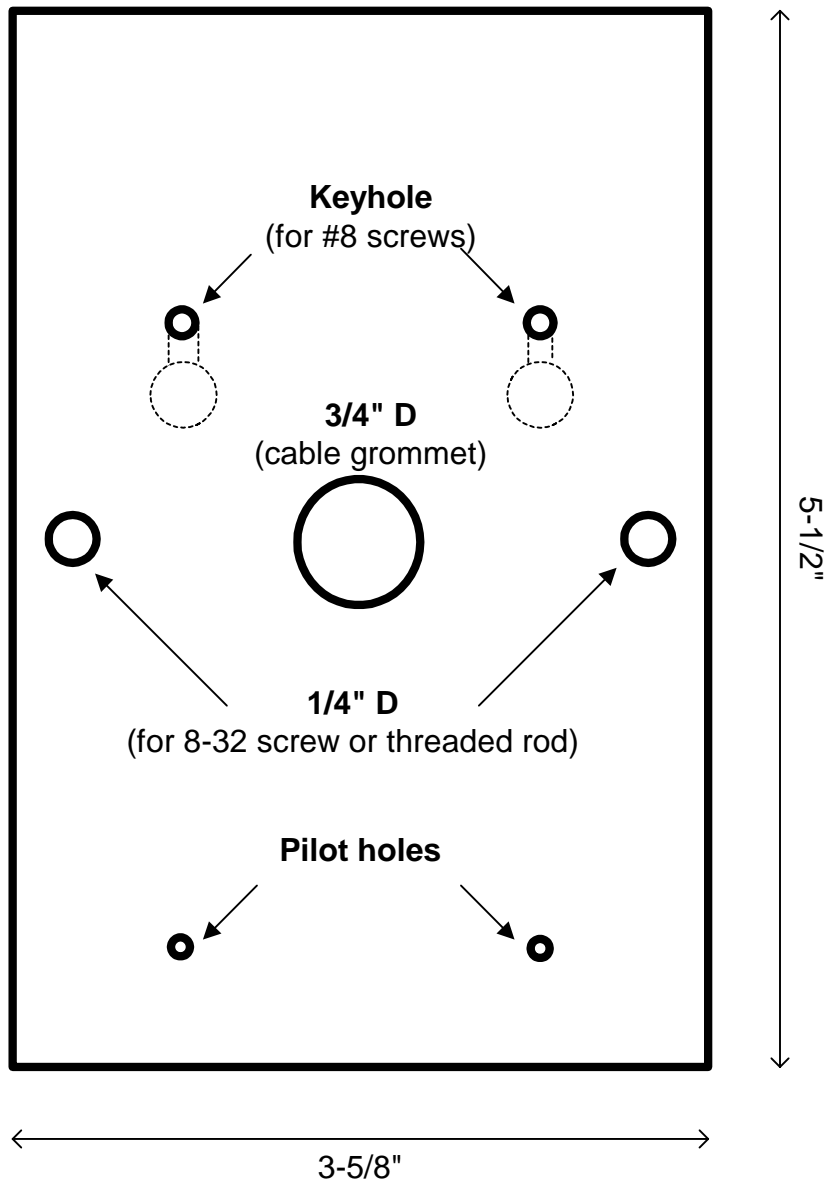

One Year Limited Warranty

MONITEQ products are warranted to be free from factory defects for a period of one year from the date of shipment. The repair or replacement of a defective part shall be at the option of the factory when the product is shipped prepaid and insured by the owner. This warranty is void in cases of abuse, misuse, mishandling, modification, or repair by unauthorized persons. This warranty is given in lieu of all other warranties expressed or implied. Moniteq is not liable for incidental or consequential damages resulting from the operation or failure of this product. This warranty recognizes any and all rights you may have under appropriate state law.

Moniteq, Inc.
700 N. Fairfax St.
Suite 604
Alexandria, VA 22314

Tel: 1-800-989-9891
Email: info@moniteq.com
Web: www.moniteq.com