

Crypto Lock

CC-8521BN

4/18

Access Control System

INSTRUCTION MANUAL



MONITEQ, Inc.

Table of Contents

1. INTRODUCTION.....	4
2. SPECIFICATIONS	6
3. SUPPLIED EQUIPMENT	7
4. FUNCTIONS OF CONTROLS AND INDICATORS	7
4.1 KEYPAD.....	7
4.2. CONTROL PANEL	7
5. INSTALLATION.....	8
5.1 GENERAL	8
5.2 INSTALLATION PROCEDURE.....	8
5.3 POWER SUPPLY SETTINGS	9
6.1 PROGRAMMING	11
6.1 GENERAL	11
6.2 PROGRAMMING INSTRUCTIONS.....	11
6.2.1 INITIAL SETTINGS	11
6.2.2 PIN MANAGEMENT.....	11
6.2.3 DOOR MONITORING.....	12
7. OPERATION	13
8. KEY PAD INSTALLATION TEMPLATE.....	15
9. CONTROL PANEL MOUNTING DIAGRAM	17

1. INTRODUCTION

Crypto-Lock is a versatile, easily installed and operated single door access control system. It provides reliable, secure access control using a single 3, 4, 5 or 6-digit PIN code for all users. It can be used with virtually all magnetic locks and electric locks and door strikes.

The system, pictured in Figure 1-1, includes a built-in 24Vdc power supply to power electric and magnetic locks, eliminating the need for a separate power supply unit. It provides the voltages and currents required to reliably open standard locking devices including heavy duty locks such as Sargent & Greenleaf BRUTE* electric locks that require high in-rush currents.

The power supply includes a battery charging and monitoring circuit that automatically maintains batteries in a fully charged condition and activates audible and visual warnings when the charge level is low. Two 12V, 7AH sealed lead acid batteries are housed in the Control Panel.

The length of time during which the lock remains released after entry of the valid PIN is programmable from 3 to 60 seconds. An invalid PIN "Penalty" feature provides for ignoring all keypad entries for 3 to 60 seconds after an invalid digit is entered. Further, if five or more successive invalid PINs are entered the penalty time is set to 60 seconds until the valid PIN is entered. This greatly reduces the possibility of gaining access by guessing PIN codes.

The system provides door monitoring functions through programmable alarms that can be used to notify of a door that has been propped or forced open. Alarms can trigger audible alerts or activate signals for use with external devices or systems. The keypad is weather resistant



Figure 1-1, the CC-852BN Control Panel and Keypad

chrome and stainless steel unit with a 20 ft shielded, water blocking cable. A green LED on the face the keypad signals the recognition of each key stroke and also illuminates when the door is released.

The # button on the keypad activates a horn in the control Panel and also generates an output signal for activating an external 24Vdc device.

Installation and set-up are readily accomplished using the wiring diagram affixed to the inside of the enclosure door and also contained in this manual.

A programming mode (which can only be activated from within the Control Panel) allows authorized personnel to set the PIN and other functions (see Table 5-1) using the keypad.

A typical installation of the Crypto Lock is illustrated in Figure 1-2.

**Brute is a registered trademark of Sargent & Greeleaf, Inc.*

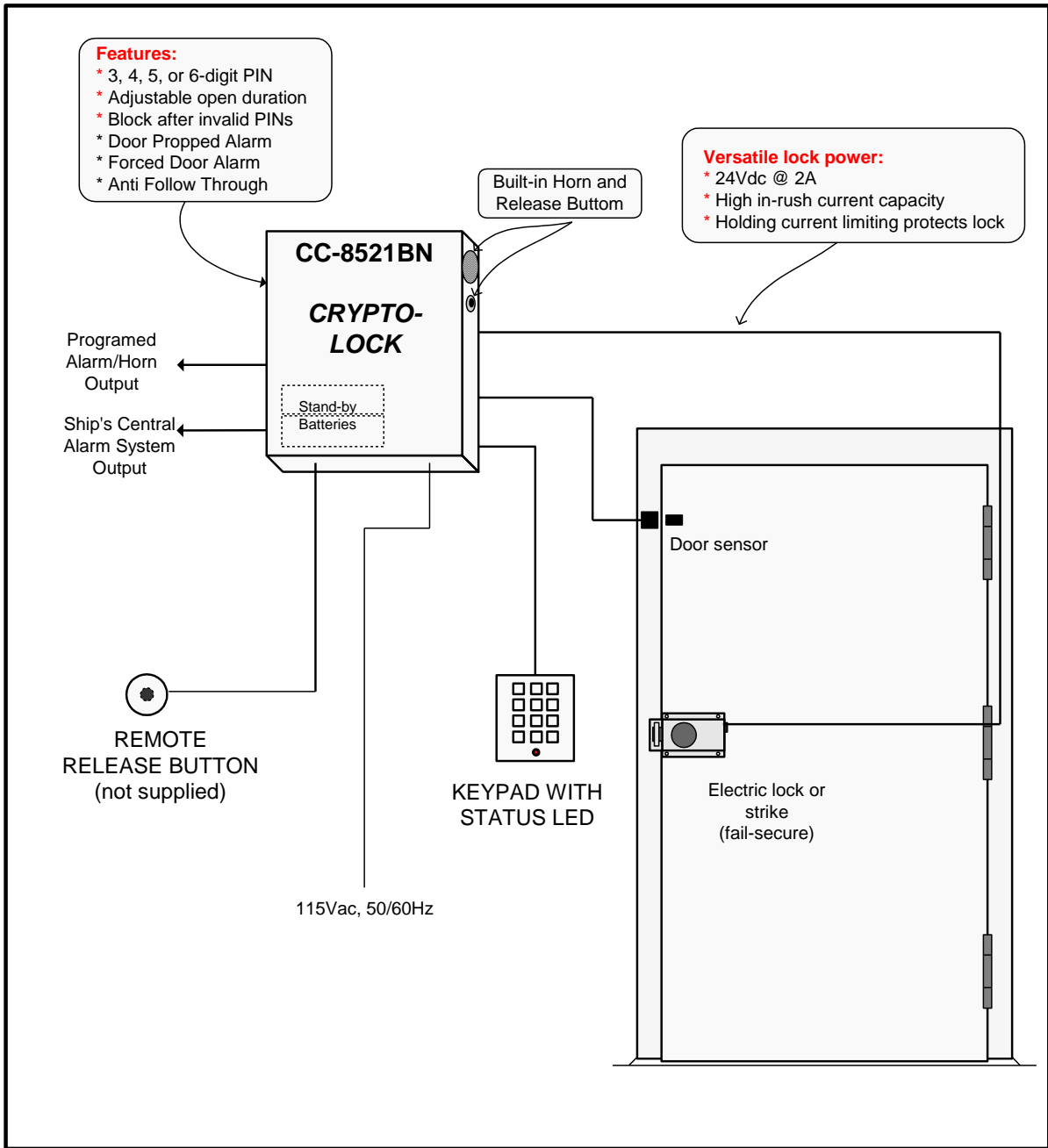

Figure 1-2, Typical Installation of the Crypto Lock Access Controller

2. SPECIFICATIONS

Power required: 115 Vac, 50 or 60 Hz, 25W

Lock Output: 24 Vdc, 2A continuous, 16A in-rush current

Horn Output: 24 Vdc

Battery back-up: 24Vdc, automatic transfer and charging (batteries optional, Moniteq Type CC-BATT)

Battery monitoring: Warning lamp, beeper and output signal activate when battery is low

PIN code length: 3, 4, 5 or 6 digits

Open duration: Programmable, 3 to 60 seconds

Penalty function: Invalid PIN attempts temporarily disable operation and can be set to sound an alarm.

Penalty time: Adjustable, 3 to 60 seconds, set to 60 seconds after five invalid PIN attempts

Remote release input: Dry contact closure

Door monitoring functions: Door propped open alarm, forced door alarm, anti-tailgating.

Keypad

Dimensions: 4.625H x 3.625W x 3.5D in.,
Weight: 3 Lbs. (with supplied 20 ft. cable)
Cable: Type LSC5OSW-4, 8-cond., #24

Enclosure: 0.09" welded aluminum, RF gasketed door, powder coated, gray color, hasp for padlock (not included)
Dimensions: 12H x 9W x 4.5D in.,
Weight: 13 Lbs. (without batteries)
Mounting: Use 3/8" x 1" long studs on bulkhead with centers located on a 14.75 H x 5.28 W inch rectangular pattern.

Options available:

CC-BATT: 12Vdc, 7AH rechargeable battery (two required for 24Vdc operation)
CC-BRUTE: Surface mounted electric lock

3. SUPPLIED EQUIPMENT

The Crypto-Lock consists of two main units, the Keypad and the Control Panel. The table below lists all of the items that

comprise the Crypto-Lock along with a brief description of each to aid in their identification and use.

QTY	ITEM	PURPOSE
1	Control Panel	Main processor and power supply
1	Keypad with 20 ft. cable	PIN code entries and programming functions
2	Threaded rod, #8 x 12"	Keypad mounting, thru-wall

4. FUNCTIONS OF CONTROLS AND INDICATORS

4.1 KEYPAD

Normal Operating Mode:

Keys 1 through 0: Used to enter the PIN code.

Key: Sounds a horn in the Control Panel and also activates a 24 Vdc output signal for use with an external device.

* Key – Not used

Green LED indicator:

Illuminates when the door is released

Flashes when any key is pressed

Programming Mode:

Keys 1 through 0: Used to enter programming codes

* Key: Used as a delimiter for programming codes and parameters.

Key: Used to terminate the programming mode.

Green LED indicator:

Programming mode: Flashes continuously

After a valid programming entry: Single flash

After an invalid programming entry: Three flashes

4.2. CONTROL PANEL

LED Indicators:

PENALTY: Illuminates when an invalid PIN has been entered on the keypad.

UNREG 24VDC: Indicates that the system is AC powered and the rectifier is functional.

REG 24VDC: Indicates that 24VDC is available for powering the lock and other external devices.

BAT: Indicates that system has no AC power and is powered by the batteries.

LOW BAT: Indicates that the battery is low.

LOCK: Indicates that the lock relay is energized.

AUX ALARM: Indicates that the Auxiliary Alarm output is active

Horn: See Table 6-1, Alarm Sequences

Fuses:

Chassis Mounted fuse holder, 2A Slo Blo, 0.25 x 1.5"

F6: 12 Vdc power, 2A, 5 x 20 mm

F7: 24Vdc power, 2A Slo Blo, 5 x 20 mm

F8: Battery power, 2A Slo Blo, 5 x 20 mm

F9: Lock power, 2A Slo Blo, 5 x 20 mm

5. INSTALLATION

5.1 GENERAL

Installation of the Crypto-Lock requires mounting the Keypad and Control Panel, connecting the Keypad, AC power, external lock, and a door switch (required to utilize door monitoring functions) to the Control Panel, and installing the batteries (optional) in the Control Panel. Programming includes setting the valid PIN code, open duration time, invalid PIN penalty time, and options for activating door propped and forced door alarms and the anti-tailgating function. Default values are provided for all of these functions except the PIN code.

5.2 INSTALLATION PROCEDURE

1. Mount the Keypad approximately 36 to 44 inches above the deck on the unsecured side of the door. Use the template at the end of this manual to mark and drill holes. If the keypad is to be flush mounted a $\frac{3}{4}$ " hole or recess at least $\frac{1}{4}$ " deep must be prepared in the mounting service to provide clearance for the cable grommet on the rear of the keypad. (See template on page 1.)

2. Mount the electric lock, strike and/or magnet according to the manufacturer's instructions.

3. Mount the Control Panel on the secure side of door using the four mounting holes. (See diagram on page 18.)

Note: All cables passing through holes made in enclosure must be protected from chafing. Route all cables to avoid the battery compartment in the bottom-left of the Control Panel.

4. Connect the Keypad to the Control Panel as shown in Figure 5-1. Twenty feet of cable is supplied with the Keypad. The Keypad can be located up to 100 feet from

Control Panel using additional cable. (Requires eight conductors, #22 or larger).

6. Connect the electric lock as shown in Figure 5-1.

7. If used, connect an external Release Button (not supplied), and external 24Vdc annunciator or horn (not supplied), as shown in Figure 5-1. Note that an internal horn in the Control Panel will sound when the Keypad's # button is pressed and for various alarm functions.

8. If the Door Propped Alarm, Forced Door Alarm or Anti-Tailgating functions will be used, connect the door switch or transducer to the Control Panel as shown in Figure 5-1. This input can be configured to accept various input signals as outlined in the Table below.

DOOR SWITCH INPUT

Jumper JP1	Door switch connections	Programming	
		*25*0* (default)	*25*1*
GND ● 24V ■	T3-3 (GND) and T3-5 (DRSW)	Open door switch activates alarm	Closed door switch activates alarm
GND ■ 24V ●	T3-4 (24V) and T3-5 (DRSW)	Closed door switch activates alarm	Open door switch activates alarm

9. If the Auxiliary Alarm Output is to be utilized connect the external system to T5-1 (Common) and either T5-2 (Normally Open) or T5-3 (Normally Closed) as appropriate. If a lock monitoring switch will be monitored connect it to T3-6 and T3-7 and remove the jumper from JP2. If a lock monitoring switch will not be used verify that a jumper is installed on JP2 (JP2 shunts the lock switch input terminals T3-6 and T3-7).

10. Install and connect the batteries as shown in Figure 5-1 using the two supplied

battery cables. Use only 12V, 7AH re-chargeable sealed batteries. (Moniteq, Inc. Type CC-BATT or equivalent.)

11. Connect the AC line cord to the Control Panel as shown in diagram below.

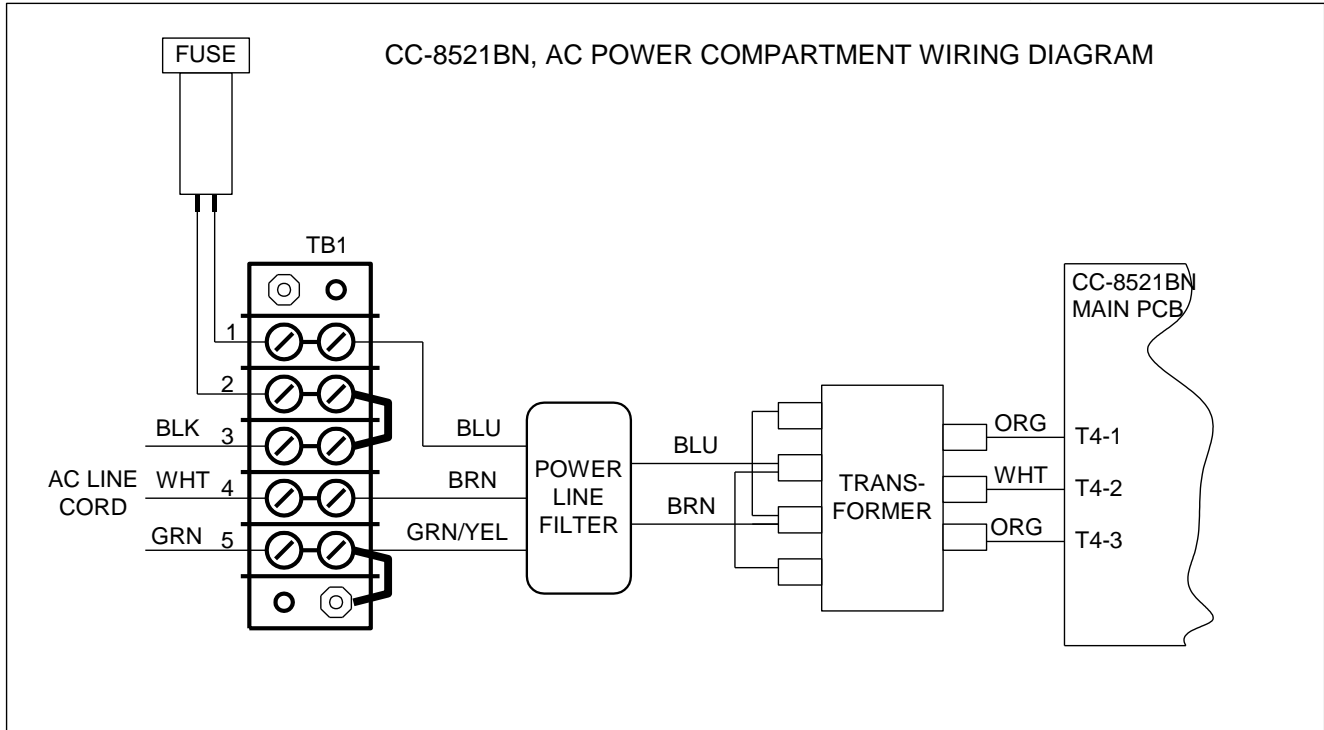

5.3 POWER SUPPLY SETTINGS

1. Connect the power cable to an appropriate source of 115 Vac 50/60 Hz power and verify that the UNREG 24VDC indicator in the Control Panel illuminates.
2. MODE Switch – In the DIReCT position 24Vdc from the power supply is applied directly to the lock. This provides up to 16 A of “in-rush” current to initially open the lock and then up to 2A continuous thereafter. Some locks including the Sargent-Greenleaf BRUTE can be damaged if powered for more than 15 seconds with unlimited current. In the LIMit position up to 16A of current is available to

initially open the lock but after the lock is open the current is limited to approximately 0.3A which is sufficient to hold the lock open for longer periods without damaging it. When using the BRUTE lock we recommend using the LIMit position if there is a possibility that the lock will be held open for more than 15 seconds. If the Brute lock will not be activated for more than 15 seconds the mode switch can be safely set to the DIReCT position.

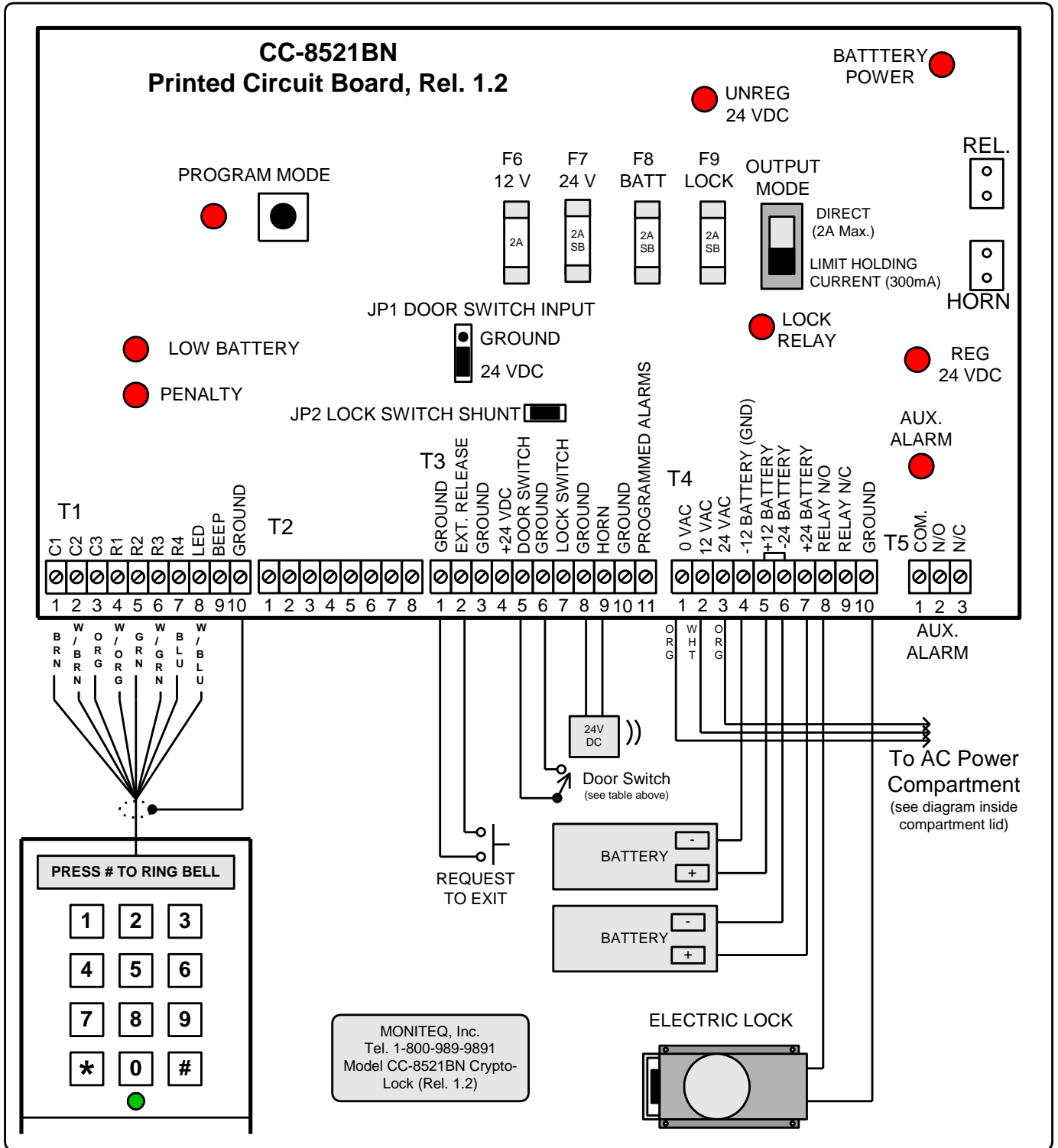

Figure 5-1, Wiring Diagram for External Devices

6.1 PROGRAMMING

6.1 GENERAL

Programming includes setting the valid PIN, open duration time, invalid PIN penalty time, and options for the door propped, and forced door alarms and anti-tailgating feature. These settings are only accessible by first placing the Control

Panel into the Programming Mode and then entering the programming sequences listed in Table 6-1 on the keypad.

Programming sequences are entered on the keypad in the form *FC*N*, where FC is a 2-digit Function Code and N is a numeric value.

Function	Sequence	Range of N	Default
PIN MANAGEMENT FUNCTIONS			
Set Defaults	*00*	N/A	N/A
Delete PIN	*10*	N/A	N/A
Set PIN	*11*N*	000 to 999, 9999, 99999 or 999999	No valid PIN
Penalty Time	*12*N*	5 to 60 (seconds)	5 seconds
Invalid PIN Alarm	*13*N*	0=Off, 1=On	Off
DOOR MANAGEMENT FUNCTIONS			
Open Duration	*20*N*	01 to 60 (sec.)	5 seconds
Anti-Follow Through	*21*N*	0=Off, 1=On	Off
Door Propped Alarm Delay Time	*22*N*	1 to 255(sec.)=On, 0=Propped Alarm Off	Off
Door Propped Alarm Duration	*23*N*	15 to 255(sec), 0=Door Closed	Door Closed
Forced Door Alarm	*24*N*	0=Off, 1=On	Off
Door Switch Sense	*25*N*	See Table	

6.2 PROGRAMMING INSTRUCTIONS

Enter the Programming Mode by pressing the PROGRAM MODE button inside the Control Panel. The red PROGRAM MODE indicator LED in the Control Panel and the green LED on the keypad will both begin to flash, verifying that the Programming Mode is active. To exit the Programming Mode and return to the Normal Operation Mode either press the PROGRAM MODE button again or press the # key on the keypad. The system will also revert to the Normal Mode if no keys are pressed for 5 minutes.

6.2.1 Initial Settings

During a new installation or if you are uncertain as to what settings have been programmed previously, it is recommended that the default values for all PIN and Door Monitoring settings be set by entering *00* on the keypad while in the Programming Mode.

6.2.2 PIN Management

A new valid PIN code can be set only when the system is in the Programming Mode. To set a new valid PIN, enter *11*N*, where N is any number containing 3, 4, 5, or 6 digits.

To delete the current valid PIN enter *10*. (This effectively disables the keypad since

no PIN can then be used to release the door.)

The CC-8521BN includes an invalid PIN penalty feature that protects against an unauthorized user gaining access by entering successive guesses of the PIN. When an invalid PIN is entered, the system then ignores all further PIN entries for 5 to 60 seconds. The default value is 5 seconds. To change the Penalty Time enter *56*N*, where N is from 5 to 60 (seconds).

After five successive invalid PIN entries the penalty time is automatically set to 60 seconds and remains at that value until the valid PIN is entered. This feature greatly increases the average time it would take to successfully guess the valid PIN and is particularly effective in protecting shorter PINs.

An Invalid PIN can be made to sound an alarm (three short beeps) whenever an invalid PIN is entered. This feature is disabled by default. To enable enter *13*1*. To disable enter *13*0*.

6.2.3 Door Monitoring

The system includes a number of functions that make it possible to monitor the status of the door during operation. With the exception of the Open Duration function, these features require that a door position sensor be installed on the door and connected to the Control Panel as illustrated in Figure 5-1.

Open Duration

The Open Duration is the time period during which the door is released (unlocked) after either a valid PIN is entered or a release button is pressed. The default Open Duration time is 5 seconds. To change the Open Duration time enter *20*N*, where N is from 5 to 60 (seconds).

Anti-Tailgating

The Anti-Tailgating mode is provided to prevent the door from being re-opened a second time during the Open Duration time period. This function is disabled by default. To enable Anti-Tailgating enter *23*1*. To disable Anti-Tailgating enter *23*0*. When this function is enabled the door re-locks immediately after it closes independent of the Open Duration setting.

Door Propped Alarm

The Door Propped Alarm function sounds an alarm when the door remains open for more than 1 to 255 seconds (Door Propped Alarm Delay Time) or until the door is closed. This function is disabled by default. To enable the Door Propped Alarm set the Door Propped Alarm Delay Time by entering *22*N* where N=1 to 255 seconds. To disable the Door Propped Alarm enter *22*0*.

The Door Propped Alarm Duration can be set to sound either continuously until the door closes, or until a time out period expires or the door closes, whichever occurs first. Enter programming code *23*0* to set the Door Propped Alarm to sound until the door closes. To have the Door Propped Alarm sound until a time out period expires or the door closes whichever occurs first, enter *23*N* where N=15 to 255 seconds (Door Propped Alarm Duration).

Forced Door Alarm

The Forced Door Alarm function sounds an alarm if the door is opened without being released by the system. This function is disabled by default. To enable the Forced Door Alarm enter *24*1*. To disable Forced Door Alarm enter *24*0*. The Forced Door Alarm is silenced by entering the valid PIN on the keypad or by disabling the Forced Door Alarm function by entering programming code *24*0*.

7. OPERATION

To operate the Crypto-Lock, enter the valid 3, 4, 5, or 6 digit PIN code on the keypad. When the valid PIN code is entered, the green LED on the Keypad will illuminate and the lock will release.

The Keypad has a built-in visitor annunciator button. Pressing the # key causes a horn to sound in the Control Panel. If an external sounding device is connected as shown in Figure 5-1 it will also sound when this button is pressed.

If an incorrect PIN code is entered the system will enter a penalty mode and will not recognize any digits for a time period of from 5 to 60 seconds. If five successive invalid PINs are entered the penalty time is set to 60 seconds until the valid PIN is entered. After the penalty time has elapsed the Panel will return to normal operation

and entering the valid PIN code on the Keypad will release the door.

The internal Release Button on the Control Panel can be used by an attendant to release the lock from a location on the secure side of the door. Similarly, if a remote release button has been installed it can also be used to release the door.

Alarms

Various alarms can be programmed to activate different horn sequences and activate 24Vdc output signals.

Internal Horn and Horn Output Signal (T3-9)

Table 7-1 lists the horn sequences and their meaning.

Table 7-1, Alarm Sequences

Alarm Type	Alarm Sequences (HORN and T3-9 Output)		Silenced by:
Visitor	Activated by # button on keypad		
Invalid PIN	- - - - -	Five short beeps	After five short beeps
Door Propped	_____	Long bursts	Door closed or time out set by code *23*N*
Forced Door	- - - - -	Short bursts	Valid PIN or code *24*0*
Low Battery	- - - -	Chirp every 15 seconds	Apply AC power
Aux. Alarm	_____	Short/long bursts	Door closed or lock released

Programmed Alarm Output (T3-11)

The output at T3-11 is similar to that described for the horn in Table 7-1 except that the Programmed Alarm output does not respond to the # button on the keypad. It only responds to alarm situations. The output is a 24 Vdc signal.

Aux Alarm Output (T5-1, 2 and 3)

The Auxiliary Alarm output is a set of Form-C dry relay contacts on T5-1, 2 and 3. The relay controlling these contacts is activated continuously when:

- a. The door switch input (T3-5 and T3-6) indicates that the door is ajar, and
 - b. The Lock Switch Input (T3-7 and T3-8) is open, and
 - c. The lock has not been released by either the valid PIN or the Release Button.
- The Auxiliary alarm Output contacts are rated at 1A maximum.

If a lock monitoring switch will be monitored remove the jumper from JP2. If a lock monitoring switch will not be used, verify that a jumper is installed on JP2 (JP2 shunts the lock switch input terminals T3-6 and T3-7).

8. KEY PAD INSTALLATION TEMPLATE

CRYPTO-LOCK Model CC-8421BN
Keypad Mounting Template

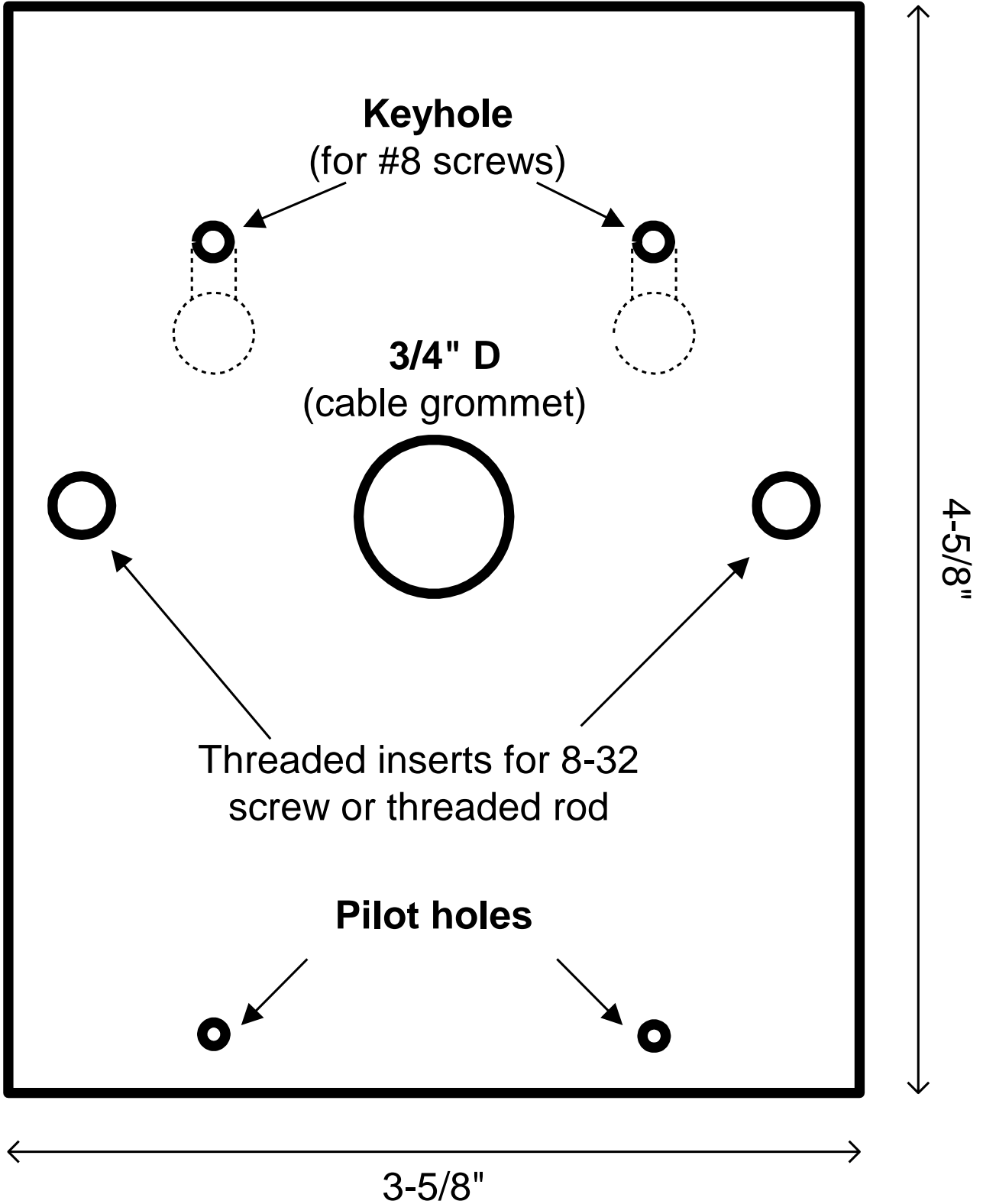

9. CONTROL PANEL MOUNTING DIAGRAM

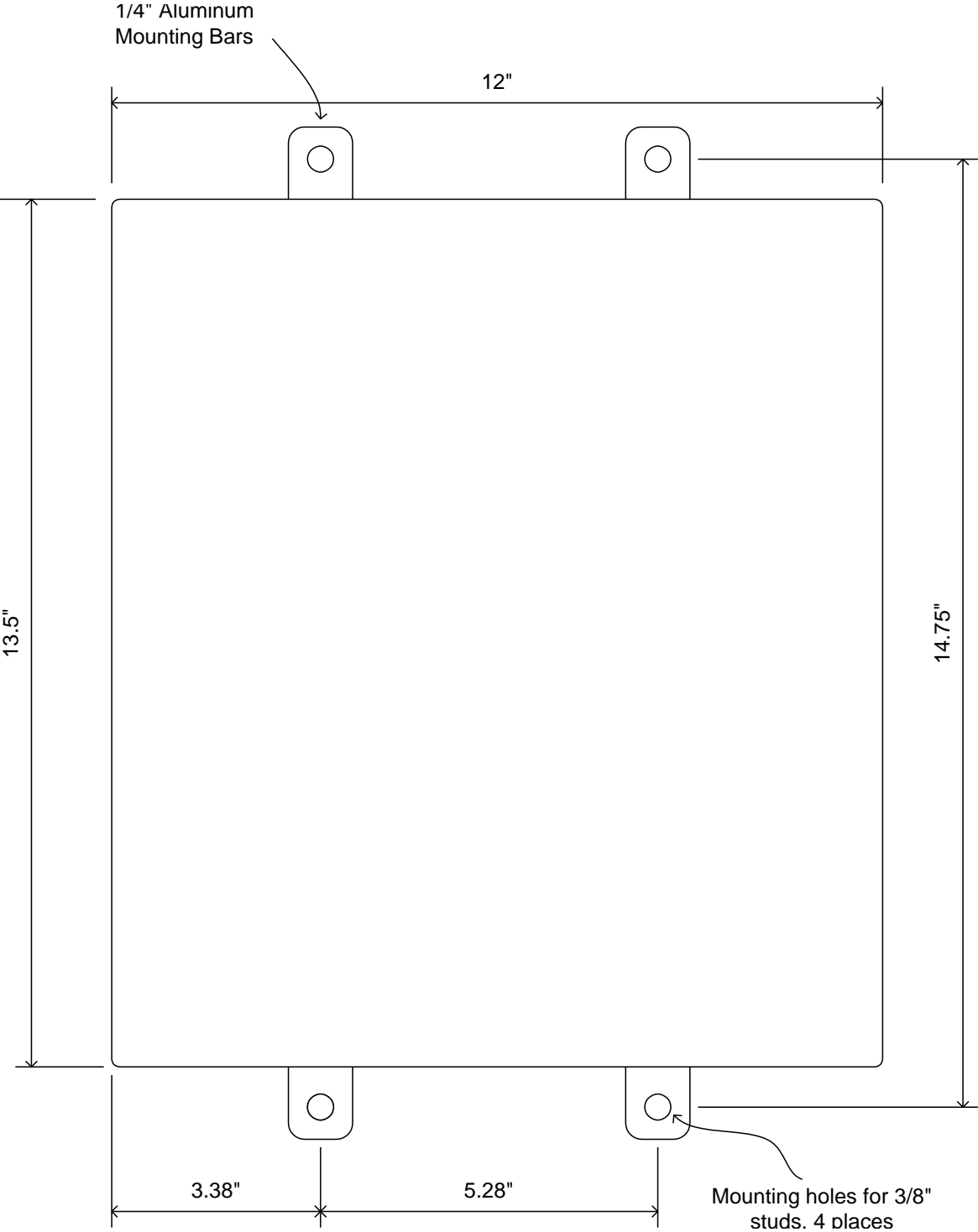

One Year Limited Warranty

MONITEQ products are warranted to be free from factory defects for a period of one year from the date of shipment. The repair or replacement of a defective part shall be at the option of the factory when the product is shipped prepaid and insured by the owner. This warranty is void in cases of abuse, misuse, mishandling, modification, or repair by unauthorized persons. This warranty is given in lieu of all other warranties expressed or implied. Moniteq, Inc. is not liable for incidental or consequential damages resulting from the operation or failure of this product. This warranty recognizes any and all rights you may have under appropriate state law.

Moniteq, Inc.
213 Church Street
Greensboro, MD 21639

Tel: 1-800-989-9891
Email: info@moniteq.com
Web: www.moniteq.com